

Please read and save these instructions. Read through this owner's manual carefully before using product. Protect yourself and others by observing all safety information, warnings, and cautions. Failure to comply with instructions could result in personal injury and/or damage to product or property. Please retain instructions for future reference.



20" NON-OSCILLATING MISTING PEDESTAL FAN

FOR CUSTOMER SERVICE

Technical Question?

CALL 1-866-458-2472
customerservice@oem-tools.com

UNPACKING

After unpacking unit, inspect carefully for any damage that may have occurred during transit. Check for loose, missing, or damaged parts. If any damage is observed, a shipping damage claim must be filed with the carrier. DO NOT use the OEMTOOLS™ 23978 20" Non-Oscillating Misting Pedestal Fan if broken, bent, cracked or damaged parts (including labels) are noted. Any Misting Pedestal Fan that appears damaged in any way, operates abnormally or is missing parts should be removed from service immediately. If you suspect that the Misting Pedestal Fan was subjected to a shock load (a load that was dropped suddenly, unexpectedly, etc.), immediately discontinue use until it has been checked by a factory authorized service center.



⚠ WARNING

The following safety information is provided as a guideline to help you operate your Pedestal Fan under the safest possible conditions. Any tool or piece of equipment can be potentially dangerous to use when safety or safe handling instructions are not known or not followed. The following safety instructions are to provide the user with the information necessary for safe use and operation. Please read and retain these instructions for the continued safe use of your Pedestal Fan. Failure to follow instructions listed below may result in serious injury. In addition, make sure that anyone who uses the equipment understands and follows these safety instructions as well.

Explanation of Safety Signal Words

⚠ WARNING: Indicates a potentially hazardous situation which, if not avoided, could result in death or serious injury.
⚠ CAUTION: Indicates a potentially hazardous situation which, if not avoided, may result in minor or moderate injury.
CAUTION: Used without the safety alert symbol indicates a potentially hazardous situation which, if not avoided, may result in property damage.

NOTES: Provide clarity and helpful information.

Thank you very much for choosing an OEMTOOLS™ Product!

For future reference, please register your new tool at www.oem-tools.com and complete the owner's record below:

Model: _____ Purchase Date: _____

Save the receipt, warranty and these instructions. It is important that you read the entire manual to become familiar with this product before you begin using it. This product is designed for certain applications only. OEMTOOLS™ cannot be responsible for issues arising from modification. We strongly recommend that this product is not modified and/or used for any application other than that for which it was designed. If you have any questions relative to a particular application, DO NOT use the product until you have first contacted customer service to determine if it can or should be performed on the product.



20" NON-OSCILLATING MISTING PEDESTAL FAN

! IMPORTANT INSTRUCTIONS AND SAFETY RULES

1. Know your product. Read this manual carefully. Learn the product's applications and limitations, as well as potential hazards specific to it.
2. Keep work area clean and well lit. Cluttered or dark work areas invite accidents.
3. Keep children away. All children should be kept away from the work area. Never let a child handle this product without strict adult supervision.
4. DO NOT operate this product if under the influence of alcohol or drugs. Read warning labels on prescriptions to determine if your judgment or reflexes are impaired while taking drugs. If there is any doubt, DO NOT attempt to operate.
5. Use safety equipment. Eye protection should be worn at all times when operating this product. Use ANSI approved safety glasses. Everyday eyeglasses are NOT safety glasses. Dust mask, non-skid safety shoes, hard hat or hearing protection should be used in appropriate conditions.
6. Wear proper apparel. Loose clothing, gloves, neck-ties, rings, bracelets or other jewelry may present a potential hazard when operating this product (or any tool). Keep all apparel clear of the tool.
7. DO NOT overreach. Keep proper footing and balance at all times when operating this product.
8. Check for damage regularly. If any part is damaged, it should be carefully inspected to make sure that it can perform its intended function correctly. If in doubt, the part should be repaired. Refer all servicing to a qualified technician. Consult your dealer for advice.
9. Keep away from flammables. DO NOT attempt to operate this product near flammable materials or combustibles. Failure to comply may cause serious injury or death.
10. When idle, store this product (and other tools) out of the reach of children and untrained persons. Tools could be dangerous in the hands of untrained users.
11. Maintain this product (and all tools) with care, keeping them dry and clean.
12. Properly maintained tools are less likely to bind and are easier to control. DO NOT use a damaged tool. Tag damaged tools "DO NOT USE" until repaired.
13. Check for misalignment or binding of moving parts, breakage of parts, and any other condition that may affect this product's operation.
14. If damaged, have this product (and any tool) serviced before using. Many accidents are caused by poorly maintained tools.
15. Use only accessories that are recommended by the manufacturer for your model. Accessories that may be suitable for one tool may become hazardous when used on another tool.
16. Service on this product must be performed only by qualified repair personnel. Service or maintenance performed by unqualified personnel could result in an injury.
17. When servicing any product, use only identical replacement parts. Use of unauthorized parts or failure to follow maintenance instructions may create a risk of injury.
18. Maintain a safe working environment. Keep the work area well lit. Make sure there is adequate surrounding workspace. Keep the work area free of obstructions, grease, oil, trash, and other debris. DO NOT use this product in a damp or wet location.
19. Maintain labels and nameplates on this product. These carry important information. If unreadable or missing, contact OEMTOOLS™ for a replacement.

IMPORTANT SAFETY INSTRUCTIONS

The warnings, precautions, and instructions discussed in this manual cannot cover all possible conditions and situations that may occur. The operator must understand that common sense and caution are factors which cannot be built into this product, but must be supplied by the operator.

DISPOSAL

At the end of the useful life of the OEMTOOLS™ Non-Oscillating Misting Pedestal Fan, dispose of the components according to all local, state, and federal regulations.

PURPOSE

The OEMTOOLS™ Fan 23978 is a 20" Non-Oscillating Pedestal Misting Fan that not only helps circulate the air and keep it in motion while maintaining a fresh breeze, but also helps to prevent the inhalation of dangerous gases and fumes by providing ventilation.

PRODUCT SPECIFICATIONS

Size	20"
Weight	14 Lbs.
Voltage	120 V/60 Hz
Current	1.15 A
CFM	5,400
RPM	1,450

SPECIFIC SAFETY INSTRUCTIONS AND WARNINGS

1. Unplug the fan before moving it or performing maintenance. DO NOT touch the fan when your hands are wet.
2. Those who are not qualified electricians should not disassemble, repair or rebuild the fan.
3. Unplug the fan when it is not in use.
4. DO NOT unplug the fan by holding the cable cord. Unplug by holding the plug.
5. DO NOT use the fan when there is damage to the cable cord or plug.
6. Avoid the use of extension cords when possible. If it is unavoidable, ensure that they are UL listed. DO NOT use a single extension cord to operate more than one fan. DO NOT plug the fan into any other cord-connected device (power strip, surge protector, multiple outlet adapters, etc.).
7. DO NOT use the fan close to any fire or heat source.
8. DO NOT insert your hand or other objects into the guard or the movable parts.
9. To reduce the risk of fire or electric shock, DO NOT use this fan with any solid-state speed control device.



20" NON-OSCILLATING MISTING PEDESTAL FAN

10. DO NOT operate any fan with a damaged cord or plug. Discard the fan or return it to an authorized service facility for examination and/or repair.
11. DO NOT run cord under carpeting. DO NOT cover cord with throw rugs, runners or similar coverings. DO NOT route cord under furniture or appliances. Arrange cord away from traffic area and where it will not be tripped over.
12. DO NOT use if electrical cord is frayed or bent.

⚠ CAUTION:

13. DO NOT immerse the fan in water or any liquid.
14. Fit the guard onto fan before starting up the fan.
15. This fan is not intended for use by people (including children) with reduced physical, sensory or mental capabilities or lack of experience and knowledge unless they have been given supervision or instructions concerning use of the fan by a person responsible for their safety. Supervise children to ensure they do not play with the fan.
16. Always place the fan on a stable, flat and level surface when operating to avoid the chance of the fan overturning.

CARE AND MAINTENANCE

Unplug the appliance before cleaning. DO NOT use any water for cleaning metal surfaces. Using a soft cloth, wipe off the surfaces of the fan. In order to remove the dust from the grill, use a vacuum cleaner or remove the front grill by removing the securing screw on the edge of the grill with a screwdriver. After cleaning, remount the grill. Then fasten 8 securing screws on the edge of the grill.

MISTING NOZZLE MAINTENANCE

If the misting nozzles become clogged, remove them from the grill and wash them with water. Use a non-metallic brush to scrub them if necessary. If the problem still exists, use the replacement nozzle or contact customer service for assistance. Never clear the nozzles with pins or other sharp objects.

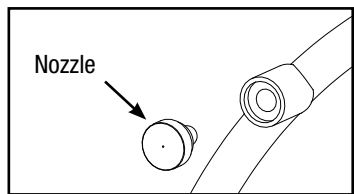

MISTING HOSE VALVE MAINTENANCE

If the misting hose valve becomes clogged, unscrew it from the garden hose and flush it with running water to remove debris, making sure the filter washer is clean.

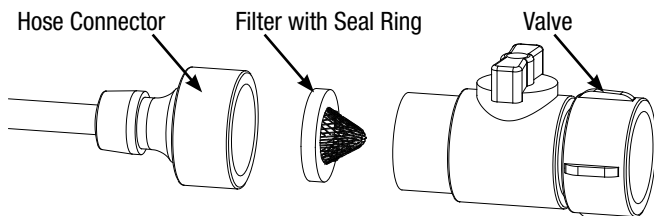

OPERATING INSTRUCTIONS

1. Test GFCI (Ground Fault Circuit Interrupter) plug BEFORE EACH USE.
 - Plug GFCI into power outlet.
 - Press RESET button (B). Indicator (A) should turn red.
 - Press TEST button (C). Indicator (A) should turn off. GFCI plug is tripped.
 - Press RESET button (B) again for use.
 - DO NOT USE FAN IF THE ABOVE TEST FAILS.
 - Call customer service for assistance.

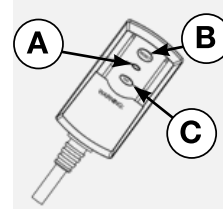

2. ADJUSTING AIR SPEED

The fan has three speeds (LOW, MEDIUM and HIGH.) Pull the chain (E) of the unit to adjust air flow to the desired speed.

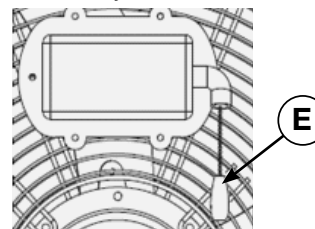

STAND ASSEMBLY INSTRUCTIONS

1. Insert 4 screws (2) through the holes in the stand pole (1), then attach the stand pole to the base (3).

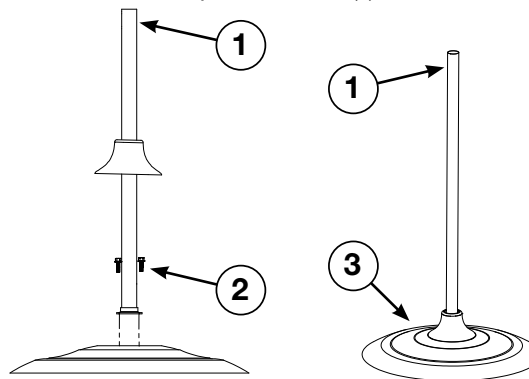

2. Insert the U-bracket on the fan body (1) into the standing pole (3), then secure with screws (2).

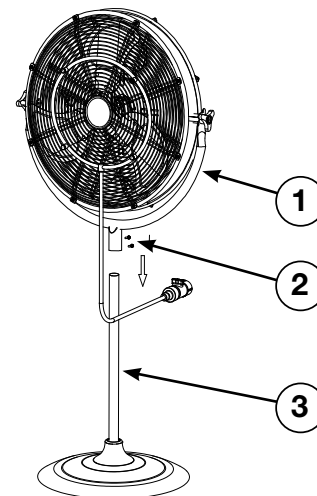



20" NON-OSCILLATING MISTING PEDESTAL FAN

3. Connect the misting switch (1) to the water pipe (2) and tighten it. Turn the switch (open) to begin the misting function. Turn the switch (close) to end the misting function.

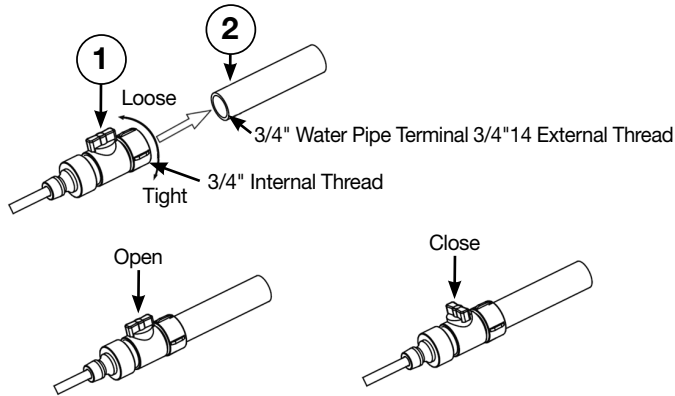

PARTS DESCRIPTION

Figure	Description	Qty.
A	Misting Device	1
B	Blade	1
C	Adjustable Knob	2
D	Switch	1
E	Capacitor	1
F	Pull Chain	1

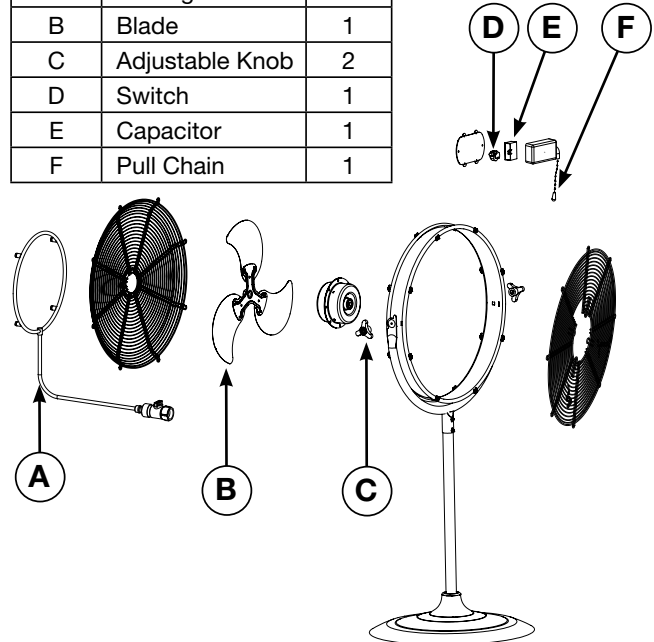

OEMTOOLS™ 90 DAY LIMITED WARRANTY

For up to 90 days from the original purchase of this OEMTOOLS™ product, if you find any defect in material or workmanship (through normal usage), return it to the place of purchase or to OEMTOOLS™ for repair or replacement at our discretion. In order to obtain this service, send your tool and proof of purchase (transportation pre-paid) to:

OEMTOOLS™ Q.A. Dept., 3580 E. Raines Road #3, Memphis, TN 38118.

We will not be responsible for lost or damaged goods during transportation; please insure your package. If our inspection verifies the defect, we will either repair or replace the product, or we may elect to refund the purchase price if we cannot readily and quickly provide you with a replacement. We will return repaired products at our expense, but if we determine there is no defect, or that the defect resulted from causes not within the scope of our warranty, then you must bear the cost of returning the product.

OEMTOOLS™ does not provide warranty for products labeled other than OEM® or OEMTOOLS™. OEMTOOLS™ will not provide any warranty for products subjected to abnormal use. Abnormal use includes (but is not limited to) abuse, accident, alteration, neglect, and unauthorized or unreasonable use or repairs. This warranty does not cover bits, blades, files, batteries, or calibration. We recommend that you maintain your tools and sharpen or replace blades, bits, files, and batteries as necessary. OEMTOOLS™ reserves the right to make any changes in construction or design at any time without any obligation in incorporating such changes to tools or equipment previously sold.

OEMTOOLS™ makes every effort to ensure that its products meet high quality and durability standards and warrants to the original purchaser that this product is free from defects in materials and workmanship for the period of 90 days from the date of purchase. This warranty does not apply to damage due directly or indirectly to misuse, abuse, negligence or accidents, repairs or alterations outside our facilities, criminal activity, improper installation, normal wear and tear, or to lack of maintenance.

We shall in no event be liable for death, injuries to persons or property, or for incidental, contingent, special or consequential damages arising from the use of our product. Some states do not allow the exclusion or limitation of incidental or consequential damages, so the above limitation of exclusion may not apply to you. THIS WARRANTY IS EXPRESSLY IN LIEU OF ALL OTHER WARRANTIES, EXPRESS OR IMPLIED, INCLUDING THE WARRANTIES OF MERCHANTABILITY AND FITNESS. This warranty gives you specific legal rights, and you may also have other rights, which vary from state to state.

Don't forget to register your new OEMTOOLS™ product at www.oem-tools.com.

CONTACT US

3580 E. Raines Road, Suite 3, Memphis, TN 38118
 Tel: 1-866-458-2472
www.oem-tools.com